



PAR38 LED Single Optic Lamps with AirFlux Technology

13PAR38/F25 2700 DIM AF SO 6/1

Philips PAR38 LED Single Optic Lamps with AirFlux Technology improves shopping experience with superior lighting aesthetics and optimal thermal efficiency in a sleek, lightweight design.

Product data

• General Characteristics

Cap-Base	E26
Bulb	PAR38 [PAR38 mm]
Rated Avg. Life (Hours)	45000 hr
Rated Lifetime (years)	41.1 an

• Light Technical Characteristics

Color Code	WW
Color Designation	Warm White
Beam Angle	25 D
Beam Description	25D [Medium beam]
Correlated Color Temperature	2700 K
Approximate Lumens	900 Lm
Approx. MBCP	5300 cd
CRI	80
Luminous Efficacy Lamp	69.23 Lm/W
Color Temp. (Kelvin)	2700 K [CCT 2700K]
Rated Luminous Flux	900 Lm

• Electrical Characteristics

Wattage	13 W
Wattage Technical	13 W
Voltage	120 V

Line Frequency	60 Hz
Power Factor	0.9 -
Lamp Current mA	126 mA
Dimmable	Yes
Wattage Equivalent	100 W
Starting Time	0.5 s

• Measuring Conditions

Switching cycle	20000x
-----------------	--------

• Product Dimensions

Overall Length C	130 mm
Diameter D	120 mm

• Product Data

Product number	430066
Full product name	13PAR38/F25 2700 DIM AF SO 6/1
Short product name	13PAR38/F25 2700 DIM AF RO 6/1
Pieces per Sku	1
eop_pck_cfg	6
Skus/Case	6
Bar code on pack	46677430061
Bar code on case	50046677430066
Logistics code(s)	929000252204
eop_net_weight_pp	0.370 kg

Warnings and Safety

- Suitable for use in damp locations.

- Not for use in totally enclosed luminaires.



PHILIPS

PAR38 LED Single Optic Lamps with AirFlux Technology

Dimensional drawing

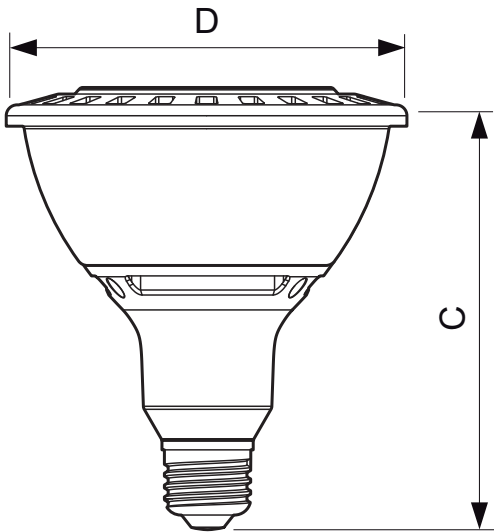

E26

13PAR38/F25 2700 DIM AF SO 6/1

Product	C (Norm)	C1 (Max)	D (Norm)	D1 (Norm)
LED 13W E26 2700K PAR38 25D DIM	130	-	120	-



© 2014 Koninklijke Philips N.V. (Royal Philips)
All rights reserved.

Specifications are subject to change without notice. Trademarks are the property of Koninklijke Philips N.V. (Royal Philips) or their respective owners.

www.philips.com/lighting

2014, March 8
data subject to change